

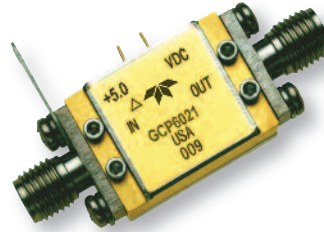

High Performance Attenuators
Typical and Guaranteed Specifications—50 Ω System



ATTENUATORS

Model	Frequency Range MHz	Insertion Loss dB		Attenuation dB		SWR In/Out		Switching Speed		Control		Bias	
		Typ.	Max. 0/50C	Typ.	Min. 0/50C	Typ.	Max. 0/50C	Typ. (s) 10-90%	Max. (s) 100%	Volts	I(mA) Max.	Volts	I(mA) Max.
Attenuators • Available in TO-8 Attenuator, Surface Mount and SMA Packages (depending on model)													
UTF-015	5-500	1.5	2.0	20	15	1.5	2.0	500	800	0 to 10	0 to 7	15	10
	500-1000	2.0	2.5	20	15	1.6	2.1	500	800	0 to 10	0 to 7	15	10
GC1275 (75Ω)	5-500	2.0	2.6	36	30	1.3	2.0	2.0	125	0 to 15	0 to 7	15	15
	5-1000	2.3	2.8	30	25	1.6	2.0	2.0	125	0 to 15	0 to 7	15	15
	5-1200	2.5	3.0	27	23	1.6	2.0	2.0	125	0 to 15	0 to 7	15	15
GC2001	5-500	2.0	2.5	36	31	1.5	2.0	2.0	125	0 to 15	0 to 7	15	15
	5-1000	2.0	2.5	30	25	1.5	2.0	2.0	125	0 to 15	0 to 7	15	15
	5-2000	2.8	3.3	23	20	1.6	2.2	2.0	125	0 to 15	0 to 7	15	15
GC2002	5-500	1.5	2.0	35	31	1.6	1.8	2.0	125	0 to 15	0 to 7	5	10
	5-1000	2.0	2.5	29	25	1.6	1.8	2.0	125	0 to 15	0 to 7	5	10
	5-2000	2.5	3.0	23	20	1.7	2.2	2.0	125	0 to 15	0 to 7	5	10
UTF-025	5-500	2.0	2.5	33	27	1.5	2.0	75	200	1 to 15	0 to 7	15	20
	500-1000	2.0	2.5	28	23	1.5	2.0	75	200	1 to 15	0 to 7	15	20
	1000-2000	2.8	3.3	23	20	1.8	2.0	75	200	1 to 15	0 to 7	15	20
	2000-2500	3.5	4.0	17	15	1.8	2.0	75	200	1 to 15	0 to 7	15	20
GC2510	10-500	2.0	2.8	52	40	1.2	1.8	<1.5	9.0	0 to 15	0 to 10	15	12
	500-1000	2.3	2.8	43	35	1.2	1.8	<1.5	9.0	0 to 15	0 to 10	15	12
	1000-2000	2.8	3.3	38	30	1.2	2.0	<1.5	9.0	0 to 15	0 to 10	15	12
	2000-2500	3.0	3.5	35	28	<1.3	2.2	<1.5	9.0	0 to 15	0 to 10	15	12
GC2530	10-500	2.0	2.8	52	40	1.2	1.8	200 ηsec	1.0	0 to 15	0 to 10	15	12
	500-1000	2.3	2.8	43	35	1.2	1.8	200 ηsec	1.0	0 to 15	0 to 10	15	12
	1000-2000	2.8	3.3	38	30	1.2	2.0	200 ηsec	1.0	0 to 15	0 to 10	15	12
	2000-2500	3.0	3.5	35	28	<1.3	2.2	200 ηsec	1.0	0 to 15	0 to 10	15	12
UTF-040	30-250	2.0	2.2	45	40	1.5	2.0	400	600	0 to -10	0 to 75	15	10
	250-500	2.0	2.2	40	35	1.5	2.0	400	600	0 to -10	0 to 75	15	10
	500-1000	2.0	2.5	35	30	1.5	2.5	400	600	0 to -10	0 to 75	15	10
UTF-030	100-500	2.0	2.5	45	40	1.7	2.0	0.5	2	0 to 15	0 to 10	15	10
	500-1000	2.5	3.0	40	35	1.7	2.0	0.5	2	0 to 15	0 to 10	15	10
	1000-2000	3.0	3.5	30	25	1.7	2.0	0.5	2	0 to 15	0 to 10	15	10
GC2534	500-1000	2.3	2.8	43	35	1.2	1.8	<100 ηsec	1.0	0 to 15	0 to 10	15	12
	1000-2000	2.8	3.3	38	30	1.2	2.0	<100 ηsec	1.0	0 to 15	0 to 10	15	12
	2000-2500	3.0	3.5	35	28	<1.3	2.2	<100 ηsec	1.0	0 to 15	0 to 10	15	12
	1000-2000	2.5	3.0	25.5	23.5	1.6	2.0	5	25	-2 to -10	0 to 40	15	50

Current data sheets available on website.



High Performance Attenuators

Typical and Guaranteed Specifications—50 Ω System

Model	Frequency Range MHz	Insertion Loss dB		Attenuation dB		SWR In/Out		Switching Speed		Control		Bias	
		Typ.	Max. 0/50C	Typ.	Min. 0/50C	Typ.	Max. 0/50C	Typ. (s) 10-90%	Max. (s) 100%	Volts	I(mA) Max.	Volts	I(mA) Max.
Attenuators • Available in TO-8 Attenuator, Surface Mount and SMA Packages (depending on model)													
GR2010 [^]	5-500	2.0	2.8	36	30	1.3	2.0	2.0	75	+2 to -10	0 to 15	15	40
	5-1000	2.3	3.0	30	25	1.6	2.0	2.0	75	+2 to -10	0 to 15	15	40
	5-2000	2.8	3.5	27	23	1.6	2.0	2.0	75	+2 to -10	0 to 15	15	40
UTF-035 ¹	50-1000	2.0	2.5	25.5	23.5	1.6	2.0	5	25	-2 to -10	0 to 40	15	50
	1000-2000	2.5	3.0	25.5	23.5	1.6	2.0	5	25	-2 to -10	0 to 40	15	50
PSF-030-25	100-1000	2.5	3.0	45	40	1.7	2.0	0.5	2.0	0 to 15	0 to 10	15	10
	1000-2000	2.5	3.0	40	35	1.7	2.0	0.5	2.0	0 to 15	0 to 10	15	10
	2000-4000	2.5	3.0	30	25	1.7	2.0	0.5	2.0	0 to 15	0 to 10	15	10
GRS6012	0.3-6000	2.0	4.5	20	18	1.8	2.0	<100 ηsec	160 ηsec	0 to -5		±5	3

Model	Frequency Range GHz	Insertion Loss dB		Attenuation dB		SWR In/Out		Switching Speed		Control	
		Typ.	Max. 0/50C	Typ.	Min. 0/50C	Typ.	Max. 0/50C	Typ. (s) 10-90%	Max. (s) 100%	Volts	I(mA) Max.
Attenuators • Available in CougarPak® Connectorized Packages											
GCP6021	2.0 - 6.0	1.5	2.5	17	15	1.5	1.8	3.8	4.5	5	26
	3.0 - 5.0	1.3	1.5	16	15	1.5	1.7	3.8	4.5	5	26
GCP8022	4.0 - 7.0	2.4	2.9	40	38	1.5	1.7	2.5	4.7	5	52
	3.0 - 8.0	3.0	3.5	40	37	1.5	1.7	2.5	4.7	5	52
GCP14021	5.0 - 8.0	2.2	2.7	22	20	2.0	2.2	2.0	4.5	5	25
	8.0 - 14.0	2.0	2.5	21	19	1.6	1.8	2.0	4.5	5	25
	14.0 - 15.0	2.8	3.0	22	20	1.3	1.5	2.0	4.5	5	25

Model	Frequency Range MHz	Typical Current Drain						Linearity Specifications [^] 10-1000 MHz Attenuation Range: 0 to 20 dB			
		Control Voltage=-10 V @ Min. Attenuation			Control Voltage=0 V @ Max. Attenuation			25°C		-55°/85°C	
		V-	V+	Vcon	V-	V+	Vcon	Typ.	Max.	Typ.	Max.
Attenuator Linearizer • Available in Linearized TO-8 Attenuator and SMA Packages											
LG2001 ¹	5-2000	5.0 mA	24.0 mA	15.0 mA	5.0 mA	11.0 mA	2.5 mA	<±1.0 dB	<±1.5 dB	<±1.5 dB	<±2.0 dB

Current data sheets available on website. ¹ Linearizer and attenuator in one package.

[^] Specifications apply to LG2001 used in conjunction with model GC2001.

GC2001

5 TO 2000 MHz TO-8 VOLTAGE CONTROLLED ATTENUATOR MODULE

Typical Values

Switching Speed (10 - 90%)	2 μsec
(0 - 100%)	< 75 μsec
Attenuation Range	> 25 dB
Low SWR	1.5:1
Excellent Flatness vs. Frequency	\pm 0.5
Standard Size TO-8 Package	

GC2001

GC2001

TO-8 Package for Attenuators

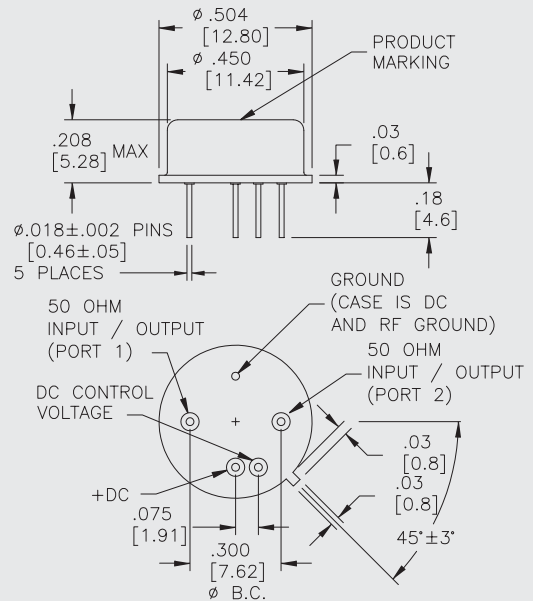

SPECIFICATIONS*

Parameter	Typical	Guaranteed	
		0 to 50 $^\circ$ C	-55 to +85 $^\circ$ C
Frequency Range	5-2100 MHz	5-2000 MHz	5-2000 MHz
Attenuation (Min.)			
5-500 MHz	36 dB	31 dB	30 dB
5-1000 MHz	30 dB	25 dB	24 dB
5-2000 MHz	23 dB	20 dB	18 dB
Insertion Loss (Max.)			
5-500 MHz	2.0 dB	2.5 dB	2.8 dB
5-1000 MHz	2.0 dB	2.5 dB	3.0 dB
5-2000 MHz	2.8 dB	3.3 dB	3.8 dB
SWR (Max.)			
Input/Output			
5-500 MHz	1.5:1	2.0:1	2.0:1
5-1000 MHz	1.5:1	2.0:1	2.0:1
5-2000 MHz	1.6:1	2.2:1	2.2:1
Flatness vs. Freq. (Max.) (Attenuation to 15 dB)			
5-1000 MHz	< \pm 0.5 dB	< \pm 1.0 dB	< \pm 1.2 dB
5-2000 MHz	< \pm 1.0 dB	< \pm 1.5 dB	< \pm 1.7 dB
Switching Speed (Max.)			
10 - 90%	2.0 μ sec	4.0 μ sec	—
0 - 100%	75 μ sec	125 μ sec	—
Bias Current (Max.)	10 mA	15 mA	15 mA
Control Voltage	0 to +15 V	0 to +15 V	0 to +15 V
Control Current (Max.)	5 mA	7 mA	7 mA

* Measured in a 50-ohm system at +15 Vdc bias.

GC2001C

TO-8 SMA Attenuator Case

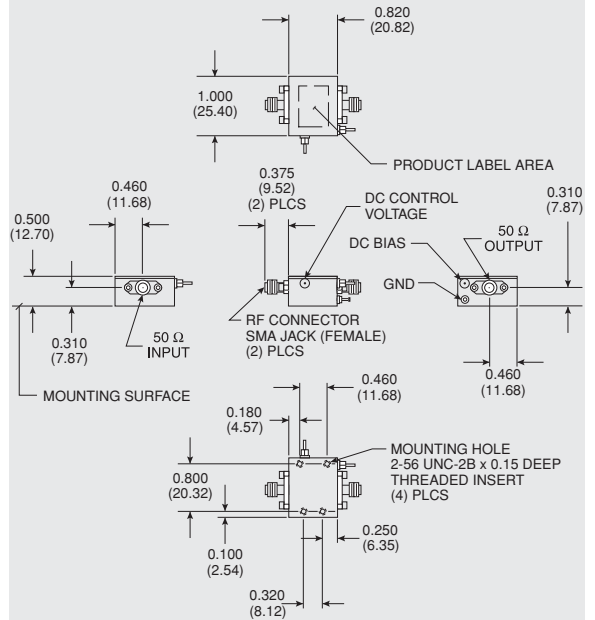

ABSOLUTE MAXIMUM RATINGS

Storage Temperature	-62 to +125 $^\circ$C
Maximum Case Temperature	+125 $^\circ$C
Maximum DC Voltage	+19 Volts
Maximum Continuous RF Input Power	200 Milliwatts
Maximum Peak Power (3 μsec Max.)	1.0 Watt
Burn-in Temperature	+125 $^\circ$C

DIMENSIONS ARE IN INCHES [MILLIMETERS]

TYPICAL PERFORMANCE

TYPICAL AUTOMATIC TEST DATA

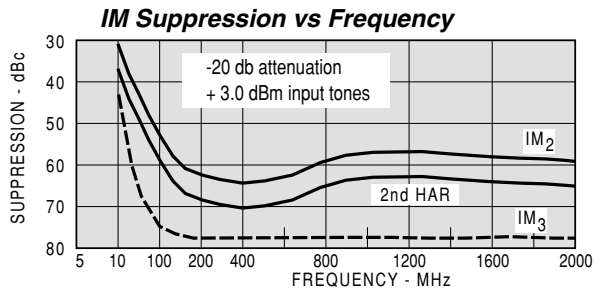
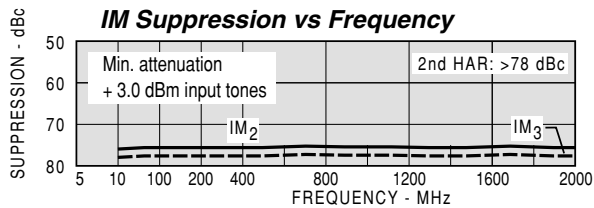
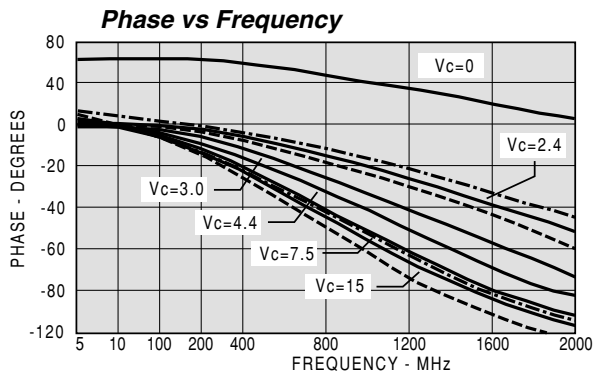
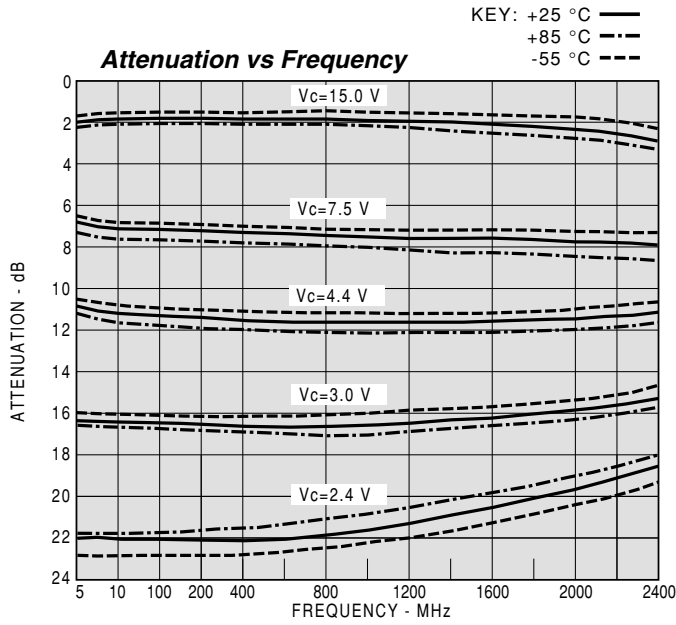

MODEL: GC2001 Vcc = +15V Icc = 9.55 Ma
Vc = 15v

FREQ MHZ	VSWR IN	VSWR OUT	GAIN DB	GROUP DELAY NSEC	REV/ISO DB
10	1.20	1.21	-1.5		-1.5
100	1.17	1.17	-1.5		-1.5
500	1.21	1.18	-1.6	0.163	-1.7
1000	1.32	1.19	-1.8	0.160	-1.9
1500	1.50	1.22	-2.1	0.161	-2.2
2000	1.66	1.21	-2.4	0.158	-2.5

MODEL: GC2001 Vcc = +15V Icc = 9.91 Ma
Vc = 3.0v

FREQ MHZ	VSWR IN	VSWR OUT	GAIN DB	GROUP DELAY NSEC	REV/ISO DB
10	1.43	1.12	-16.5		-16.5
100	1.47	1.09	-16.6		-16.6
500	1.44	1.09	-16.7	0.096	-16.7
1000	1.51	1.10	-16.4	0.098	-16.4
1500	1.44	1.09	-16.0	0.106	-16.0
2000	1.45	1.05	-15.4	0.114	-15.5

MODEL: GC2001 Vcc = +15V Icc = 9.96 Ma
Vc = 0v

FREQ MHZ	VSWR IN	VSWR OUT	GAIN DB	GROUP DELAY NSEC	REV/ISO DB
10	1.25	1.32	-63.4		-63.3
100	1.26	1.22	-47.4		-47.5
500	1.26	1.21	-35.4	0.047	-35.3
1000	1.24	1.20	-29.4	0.093	-29.4
1500	1.24	1.22	-25.7	0.114	-25.8
2000	1.35	1.28	-23.1	0.127	-23.1

MODEL: GC2001 Vcc = +12V Icc = 7.63 Ma
Vc = 12v

FREQ MHZ	VSWR IN	VSWR OUT	GAIN DB	GROUP DELAY NSEC	REV/ISO DB
10	1.25	1.26	-1.7		-1.7
100	1.22	1.22	-1.7		-1.7
500	1.26	1.23	-1.9	0.162	-1.9
1000	1.33	1.21	-2.0	0.162	-2.0
1500	1.56	1.21	-2.3	0.160	-2.3
2000	1.71	1.19	-2.6	0.162	-2.6

MODEL: GC2001 Vcc = +12V Icc = 7.88 Ma
Vc 3.0v

FREQ MHZ	VSWR IN	VSWR OUT	GAIN DB	GROUP DELAY NSEC	REV/ISO DB
10	1.23	1.15	-13.0		-13.0
100	1.24	1.05	-13.0		-13.0
500	1.24	1.03	-13.2	0.121	-13.1
1000	1.37	1.02	-13.2	0.121	-13.2
1500	1.44	1.04	-13.2	0.123	-13.2
2000	1.56	1.07	-13.0	0.127	-13.1

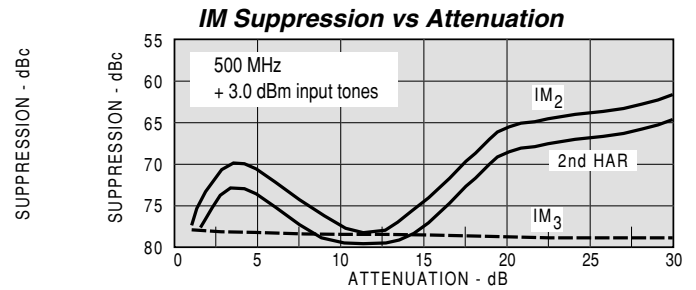

GC2510 10 TO 2500 MHz TO-8 VOLTAGE CONTROLLED ATTENUATOR MODULE

Typical Values	GC2510
Fast Switching (10 - 90%)	< 1.5 μ sec
(0 - 100%)	< 8 μ sec
High Attenuation Range	> 35 dB
Low SWR	< 1.5:1
Excellent Flatness vs. Frequency	\pm 0.5
Standard Size TO-8 Package for Attenuators	

SPECIFICATIONS*

Parameter	Typical	Guaranteed	
		0 to 50 °C	-55 to +85 °C
Frequency Range	10-2600 MHz	10-2500 MHz	10-2500 MHz
Attenuation (Min.)			
10-20 MHz	40 dB	37 dB	34 dB
20-500 MHz	52 dB	40 dB	37 dB
500-1000 MHz	43 dB	35 dB	32 dB
1000-2000 MHz	38 dB	30 dB	27 dB
2000-2500 MHz	35 dB	28 dB	25 dB
Insertion Loss (Max.)			
10-500 MHz	2.0 dB	2.8 dB	3.0 dB
500-1000 MHz	2.3 dB	2.8 dB	3.2 dB
1000-2000 MHz	2.8 dB	3.3 dB	3.8 dB
2000-2500 MHz	3.0 dB	3.5 dB	4.2 dB
SWR (Max.)			
Input/Output			
10-1000 MHz	1.2:1	1.8:1	1.8:1
1000-2000 MHz	1.2:1	2.0:1	2.0:1
2000-2500 MHz	< 1.3:1	2.2:1	2.2:1
Flatness vs. Freq. (Max.) (Attenuation to 25 dB)			
10-1000 MHz	< \pm 0.5 dB	< \pm 1.0 dB	< \pm 1.0 dB
1000-2500 MHz	< \pm 1.0 dB	< \pm 1.5 dB	< \pm 1.7 dB
Switching Speed (Max.)			
10 - 90%	< 1.5 μ sec	2.0 μ sec	—
0 - 100%	< 8.0 μ sec	9.0 μ sec	—
Bias Current (Max.)	7 mA	10 mA	12 mA
Control Voltage	0 to +15 V	0 to +15 V	0 to +15 V
Control Current (Max.)	7 mA	10 mA	10 mA

* Measured in a 50-ohm system at +15 Vdc bias.

ABSOLUTE MAXIMUM RATINGS

Storage Temperature	-62 to +125 °C
Maximum Case Temperature	+125 °C
Maximum DC Voltage	+19 Volts
Maximum Continuous RF Input Power	200 Milliwatts
Maximum Peak Power (3 μsec Max.)	1.0 Watt
Burn-in Temperature	+125 °C

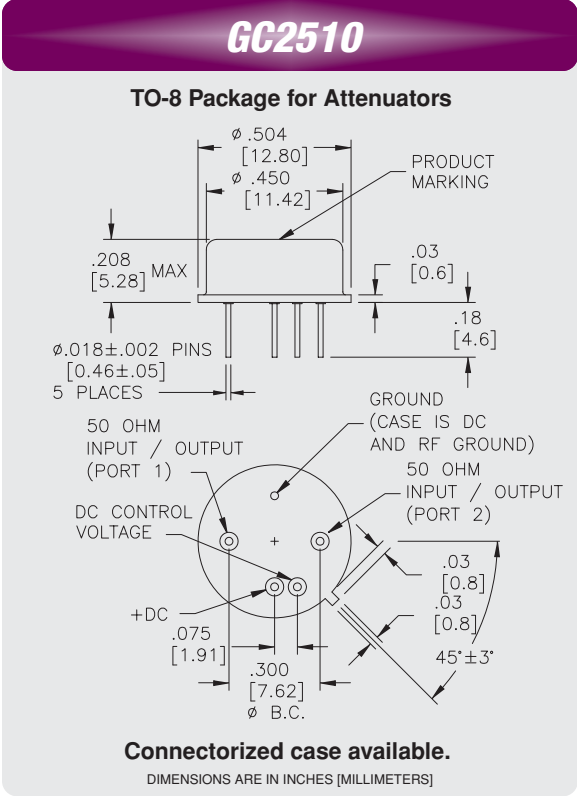

SWITCHING SPEED

Typical Switching Speed at 25 °C

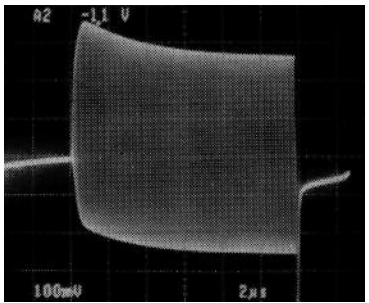

Full Attenuation Range

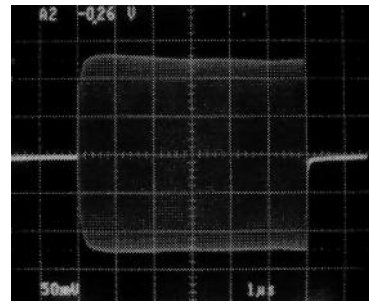

10 dB Attenuation Range

TYPICAL PERFORMANCE

TYPICAL AUTOMATIC TEST DATA

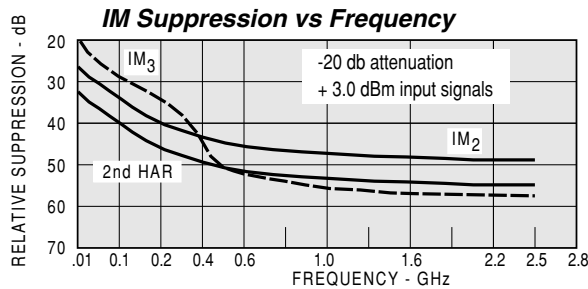
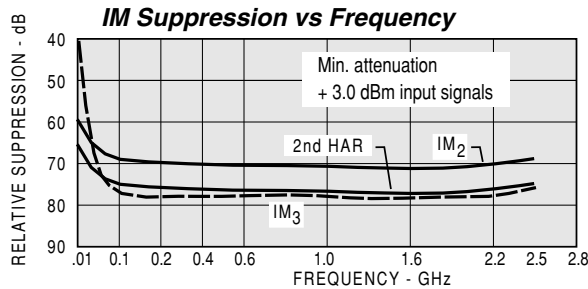
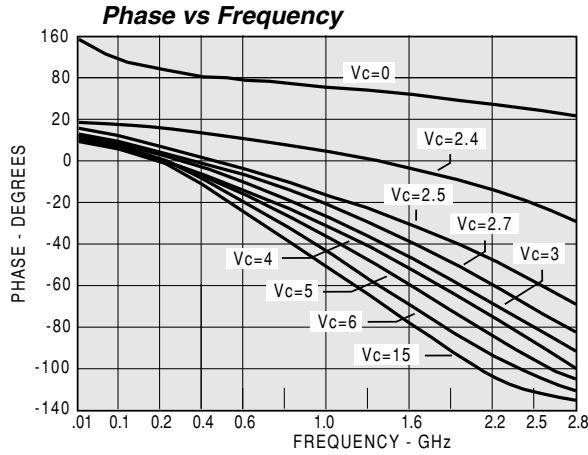
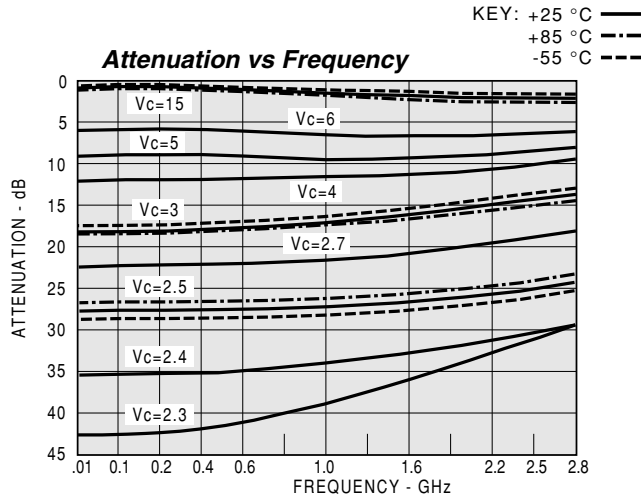

Model: GC2510 Vcc=+15V Icc=4.84 mA
Vc=+15V

FREQ MHZ	SWR IN	SWR OUT	GAIN DB	GROUP DELAY NSEC	REVI/ISO DB
10.0	1.51	1.50	-1.9		-1.9
100.0	1.20	1.20	-1.5		-1.5
500.0	1.20	1.20	-1.6	.145	-1.6
1000.0	1.21	1.23	-1.8	.136	-1.7
1500.0	1.32	1.29	-2.0	.134	-2.0
2000.0	1.34	1.35	-2.3	.135	-2.2
2500.0	1.35	1.33	-2.4	.132	-2.5

Model: GC2510 Vcc=+15V Icc=5.02 mA
Vc=+4.0V

FREQ MHZ	SWR IN	SWR OUT	GAIN DB	GROUP DELAY NSEC	REVI/ISO DB
10.0	1.60	1.58	-12.8		-12.8
100.0	1.32	1.34	-12.1		-12.1
500.0	1.33	1.37	-12.1	.113	-12.1
1000.0	1.37	1.37	-12.0	.100	-11.9
1500.0	1.28	1.33	-11.7	.102	-11.7
2000.0	1.21	1.23	-11.2	.109	-11.3
2500.0	1.02	1.07	-10.5	.122	-10.5

Model: GC2510 Vcc=+15V Icc=5.14 mA
Vc=+2.5V

FREQ MHZ	SWR IN	SWR OUT	GAIN DB	GROUP DELAY NSEC	REVI/ISO DB
10.0	1.61	1.58	-31.2		-31.3
100.0	1.09	1.10	-28.9		-28.9
500.0	1.05	1.09	-28.4	.088	-28.3
1000.0	1.10	1.10	-28.3	.071	-28.2
1500.0	1.10	1.11	-27.9	.063	-27.9
2000.0	1.21	1.19	-27.2	.082	-27.5
2500.0	1.49	1.43	-26.5	.118	-26.7

Model: GC2510 Vcc=+15V Icc=5.15 mA
Vc=+0V

FREQ MHZ	SWR IN	SWR OUT	GAIN DB	GROUP DELAY NSEC	REVI/ISO DB
10.0	1.63	1.59	-55.6		-54.2
100.0	1.09	1.08	-63.6		-65.6
500.0	1.08	1.05	-47.6	.135	-46.9
1000.0	1.13	1.12	-40.4	.095	-41.3
1500.0	1.22	1.19	-37.2	.089	-37.2
2000.0	1.38	1.35	-34.9	.086	-35.0
2500.0	1.77	1.68	-33.8	.093	-33.6

Model: GC2510 Vcc=+12V Icc=4.06 mA
Vc=+2.5V

FREQ MHZ	SWR IN	SWR OUT	GAIN DB	GROUP DELAY NSEC	REVI/ISO DB
10.0	1.67	1.63	-19.4		-19.5
100.0	1.12	1.13	-18.1		-18.1
500.0	1.06	1.10	-17.8	.113	-17.8
1000.0	1.09	1.10	-17.6	.096	-17.5
1500.0	1.02	1.06	-17.3	.098	-17.3
2000.0	1.05	1.04	-16.8	.104	-16.8
2500.0	1.26	1.21	-16.1	.122	-16.2

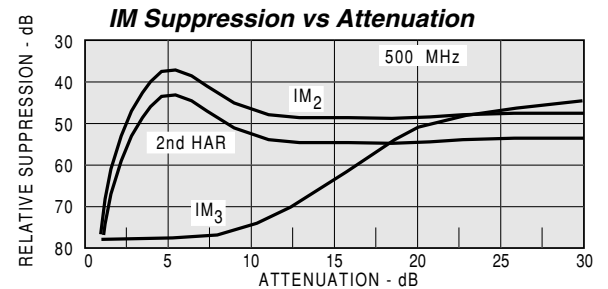

GC2530 100 TO 2500 MHz TO-8 VOLTAGE CONTROLLED ATTENUATOR MODULE

Typical Values	GC2530
Fast Switching (10 - 90%)	200 ns
(0 - 100%)	700 ns
High Attenuation Range	> 35 dB
Low SWR	< 1.5:1
Excellent Flatness vs. Frequency	± 0.5
Standard Size TO-8 Package	

SPECIFICATIONS*

Parameter	Typical	Guaranteed	
		0 to 50 °C	-55 to +85 °C
Frequency Range	50-2600 MHz	100-2500 MHz	100-2500 MHz
Attenuation (Min.)			
100-500 MHz	52 dB	40 dB	37 dB
500-1000 MHz	43 dB	35 dB	32 dB
1000-2000 MHz	38 dB	30 dB	27 dB
2000-2500 MHz	35 dB	28 dB	25 dB
Insertion Loss (Max.)			
100-500 MHz	2.0 dB	2.8 dB	3.0 dB
500-1000 MHz	2.3 dB	2.8 dB	3.2 dB
1000-2000 MHz	2.8 dB	3.3 dB	3.8 dB
2000-2500 MHz	3.0 dB	3.5 dB	4.2 dB
SWR (Max.)			
Input/Output			
100-1000 MHz	1.2:1	1.8:1	1.8:1
1000-2000 MHz	1.2:1	2.0:1	2.0:1
2000-2500 MHz	< 1.3:1	2.2:1	2.2:1
Flatness vs. Freq. (Max.) (Attenuation to 25 dB)			
100-1000 MHz	< ±0.5 dB	< ±1.0 dB	< ±1.0 dB
1000-2500 MHz	< ±1.0 dB	< ±1.5 dB	< ±1.7 dB
Switching Speed (Max.)			
10 - 90%	200 ns	400 ns	—
0 - 100%	700 ns	1.0 µsec	—
Bias Current (Max.)	7 mA	10 mA	12 mA
Control Voltage	0 to +15 V	0 to +15 V	0 to +15 V
Control Current (Max.)	7 mA	10 mA	10 mA

* Measured in a 50-ohm system at +15 Vdc bias.

ABSOLUTE MAXIMUM RATINGS

Storage Temperature	-62 to +125 °C
Maximum Case Temperature	+125 °C
Maximum DC Voltage	+19 Volts
Maximum Continuous RF Input Power	200 Milliwatts
Maximum Peak Power (3 µsec Max.)	1.0 Watt
Burn-in Temperature	+125 °C

GC2530

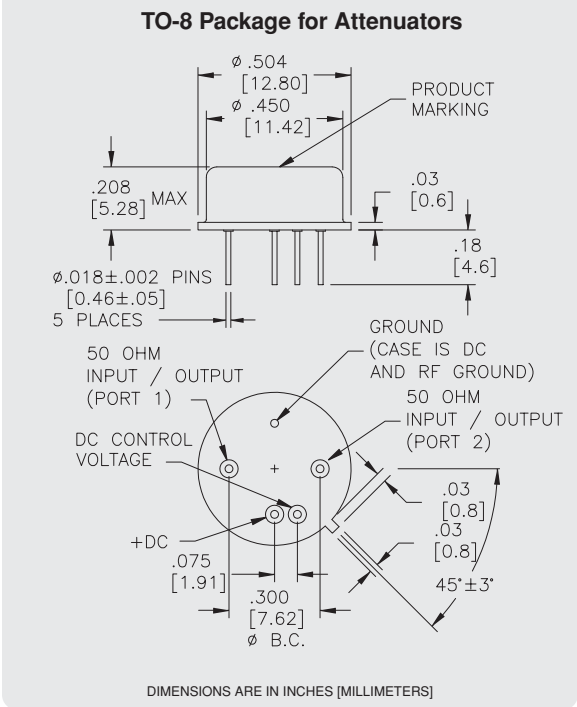

SWITCHING SPEED

Typical Switching Speed at 25 °C

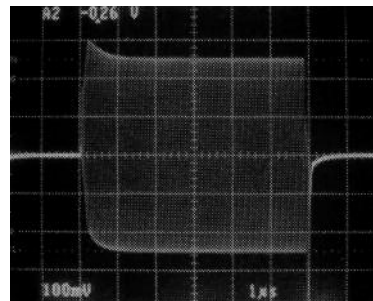

Full Attenuation Range

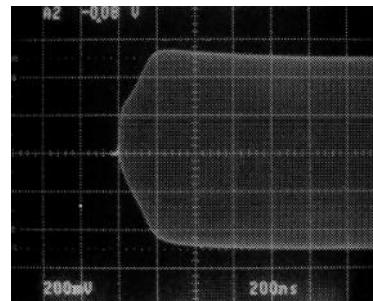

10 dB Attenuation Range

TYPICAL PERFORMANCE

TYPICAL AUTOMATIC TEST DATA

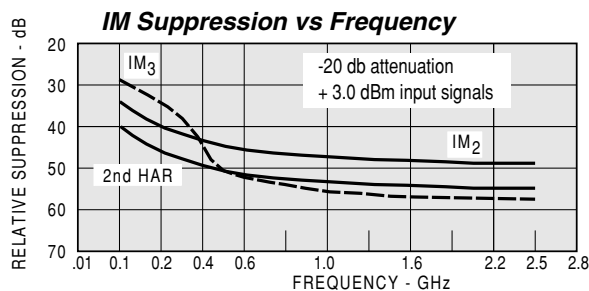
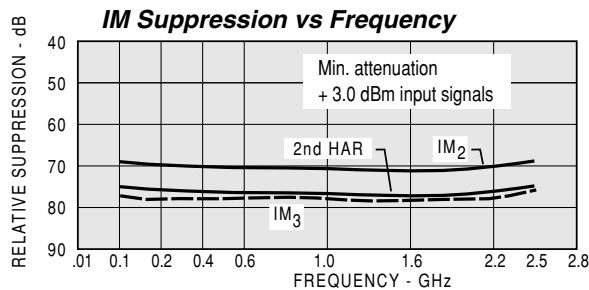
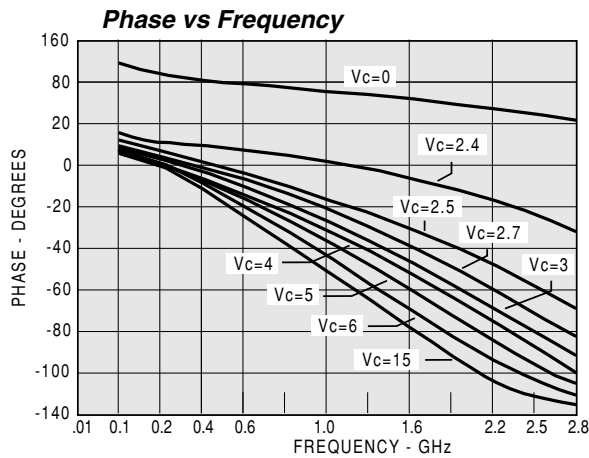
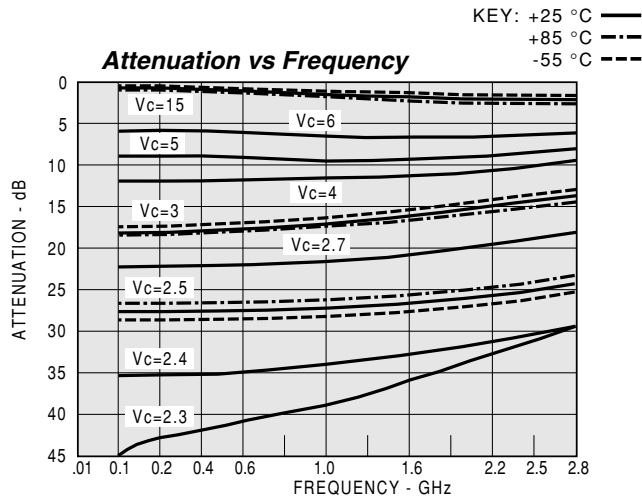

MODEL: GC2530 Vcc = +15V Icc = 5.75 Ma
Vc = 15v

FREQ MHZ	VSWR IN	VSWR OUT	GAIN DB	GROUP DELAY NSEC	REV/ISO DB
100	1.35	1.36	-1.4	0.183	-1.4
500	1.17	1.18	-1.4	0.183	-1.4
1000	1.21	1.23	-1.5	0.140	-1.5
1500	1.30	1.32	-1.8	0.135	-1.8
2000	1.37	1.43	-2.5	0.119	-2.4
2500	1.32	1.37	-2.2	0.142	-2.2

MODEL: GC2530 Vcc = +15V Icc = 5.99 Ma
Vc = 4.0v

FREQ MHZ	VSWR IN	VSWR OUT	GAIN DB	GROUP DELAY NSEC	REV/ISO DB
100	1.78	1.77	-12.0	0.130	-12.0
500	1.69	1.67	-11.8	0.130	-11.8
1000	1.68	1.65	-11.6	0.097	-11.6
1500	1.61	1.56	-11.3	0.096	-11.3
2000	1.36	1.34	-10.9	0.100	-10.8
2500	1.30	1.25	-10.0	0.118	-10.1

MODEL: GC2530 Vcc = +15V Icc = 6.12 Ma
Vc = 2.5v

FREQ MHZ	VSWR IN	VSWR OUT	GAIN DB	GROUP DELAY NSEC	REV/ISO DB
100	1.47	1.45	-28.9	0.093	-28.8
500	1.24	1.21	-27.9	0.093	-27.9
1000	1.23	1.19	-27.4	0.057	-27.4
1500	1.18	1.14	-26.9	0.061	-26.9
2000	1.12	1.12	-26.4	0.082	-26.4
2500	1.28	1.30	-25.2	0.081	-25.2

MODEL: GC2530 Vcc = +15V Icc = 6.13 Ma
Vc = 0v

FREQ MHZ	VSWR IN	VSWR OUT	GAIN DB	GROUP DELAY NSEC	REV/ISO DB
100	1.43	1.41	-55.7	0.326	-55.9
500	1.14	1.11	-46.5	0.326	-46.6
1000	1.16	1.12	-39.9	0.069	-40.0
1500	1.18	1.15	-36.1	0.072	-36.2
2000	1.28	1.29	-33.7	0.082	-33.8
2500	1.52	1.54	-31.2	0.086	-31.2

MODEL: GC2530 Vcc = +12V Icc = 4.84Ma
Vc = 2.5v

FREQ MHZ	VSWR IN	VSWR OUT	GAIN DB	GROUP DELAY NSEC	REV/ISO DB
100	1.51	1.50	-17.5	0.121	-17.5
500	1.34	1.32	-17.1	0.121	-17.0
1000	1.32	1.30	-16.7	0.090	-16.7
1500	1.27	1.23	-16.3	0.092	-16.3
2000	1.07	1.06	-15.9	0.100	-15.8
2500	1.05	1.05	-14.9	0.110	-14.8

