

AR2538

20 TO 2500 MHz TO-8B CASCADABLE AMPLIFIER

Typical Values

High Gain	AR2538 21.0 dB
High Output Power	+26.0 dBm
Low Noise Figure	3.5 dB
High Performance Thin Film Standard Size TO-8B Package	

SPECIFICATIONS*

Parameter	Typical	Guaranteed	
		0 to 50 °C	-55 to +85 °C
Frequency (Min.)	20-2600 MHz	20-2500 MHz	20-2500 MHz
Small Signal Gain (Min.)	21.0 dB	20.0 dB	19.5 dB
Gain Flatness (Max.)	±0.5 dB	±0.8 dB	±1.0 dB
Noise Figure (Max.) 100-2500 MHz	3.5 dB	4.0 dB	4.5 dB
SWR (Max.) Input/Output	<1.6:1	1.8:1	2.0:1
Power Output (Min.) @ 1dB comp.	+26.0 dBm	+24.5 dBm	+24.0 dBm
Reverse Isolation	37.0 dB	—	—
DC Current (Max.)	190 mA	195 mA	200 mA

* Measured in a 50-ohm system at +15 Vdc unless otherwise specified.

INTERMODULATION PERFORMANCE

Typical @ 25 °C; 1000 MHz

Second Order Harmonic Intercept Point	AR2538 +58 dBm
Second Order Two Tone Intercept Point	+52 dBm
Third Order Two Tone Intercept Point	+39 dBm

ABSOLUTE MAXIMUM RATINGS

Storage Temperature	-65 to 160 °C
Maximum Case Temperature	+120 °C
Maximum DC Voltage	+20 Volts
Maximum Continuous RF Input Power	+20 dBm
Burn-in Temperature	+100 °C
Thermal Resistance (θjc)	+33 °C/Watt
Junction Temperature Rise Above Case (Tjc)	+50 °C

AR2538

TO-8B Package for Amplifiers

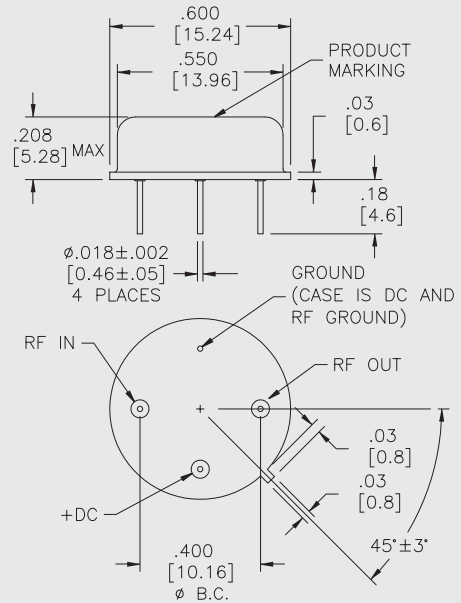

ARS2538

SMT0-8B Package for Amplifiers

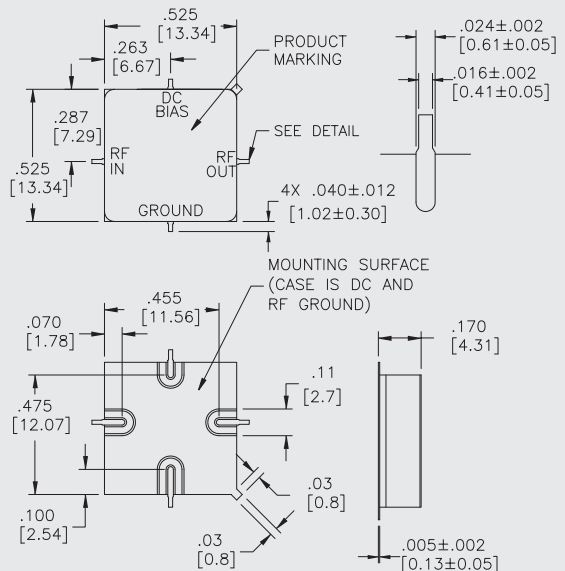

DIMENSIONS ARE IN INCHES [MILLIMETERS]

TYPICAL PERFORMANCE

TYPICAL AUTOMATIC TEST DATA

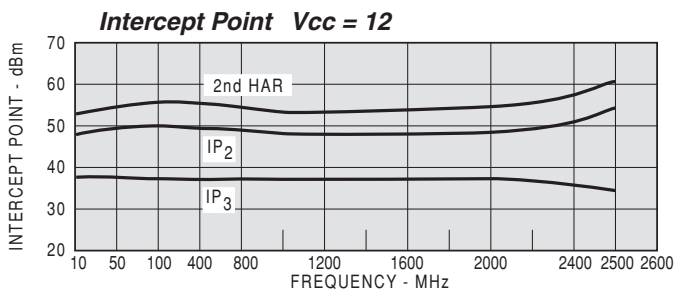
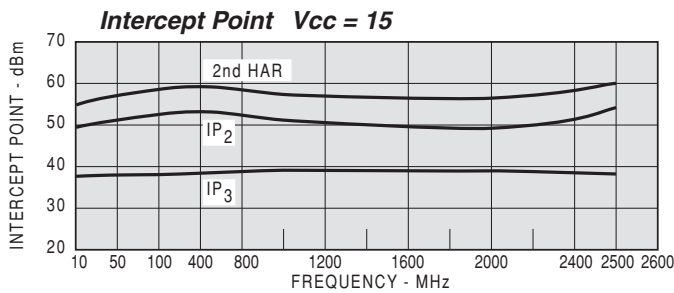
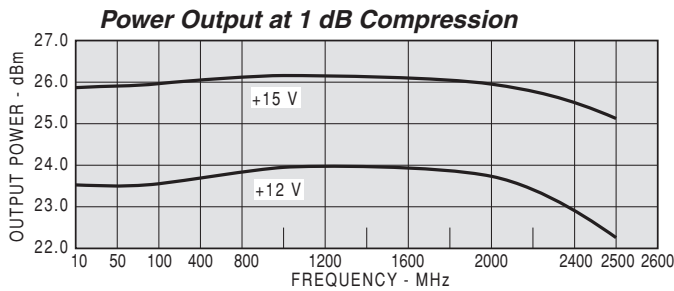
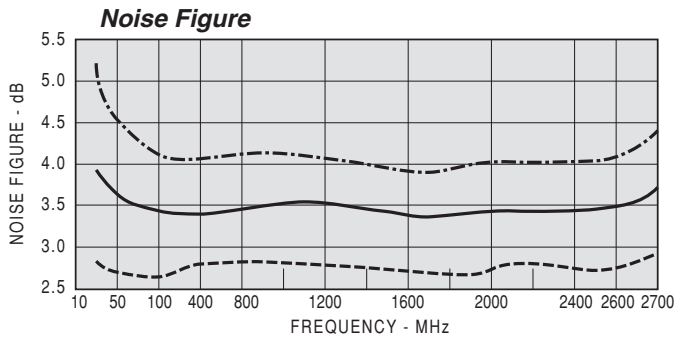
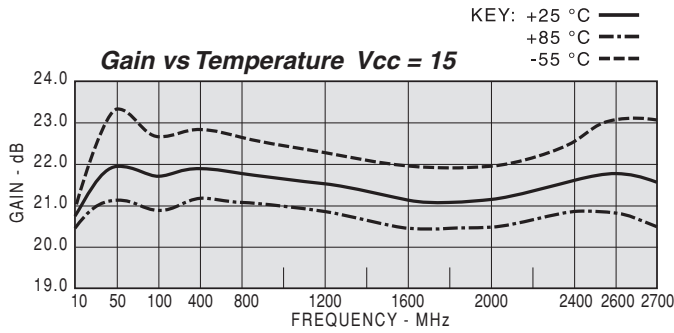

Model: AR2538		Vcc=+15V				Icc=189.00	
FREQ	SWR	SWR	GAIN	PHASE	GROUP DELAY	REV/ISO	
MHZ	IN	OUT	DB	DEG	NSEC	DB	
5	2.87	4.73	14.67	118		-36.00	
10	1.90	2.55	20.73	65		-36.10	
15	1.53	1.91	21.89	41		-36.50	
20	1.38	1.67	22.15	28		-37.00	
50	1.19	1.44	22.18	4		-36.80	
100	1.16	1.37	21.99	-11	0.83	-36.70	
150	1.16	1.36	21.79	-19	0.44	-36.70	
200	1.24	1.41	21.60	-26	0.39	-36.20	
250	1.27	1.38	21.85	-32	0.36	-36.70	
300	1.28	1.36	22.02	-40	0.46	-36.90	
350	1.30	1.36	22.08	-48	0.44	-36.90	
400	1.32	1.36	22.11	-56	0.44	-36.70	
500	1.36	1.39	22.10	-72	0.43	-37.00	
600	1.40	1.42	22.04	-87	0.42	-37.10	
700	1.44	1.44	21.96	-103	0.42	-37.20	
800	1.48	1.47	21.91	-118	0.41	-37.40	
900	1.51	1.48	21.81	-133	0.42	-37.40	
1000	1.53	1.48	21.72	-147	0.41	-37.70	
1100	1.54	1.47	21.65	-162	0.41	-38.00	
1200	1.55	1.47	21.59	-177	0.41	-37.60	
1300	1.54	1.45	21.49	168	0.42	-37.70	
1400	1.50	1.45	21.32	154	0.41	-37.40	
1500	1.47	1.42	21.23	139	0.39	-38.10	
1600	1.44	1.38	21.17	125	0.40	-37.30	
1700	1.41	1.38	21.10	111	0.40	-37.60	
1800	1.39	1.38	21.12	96	0.40	-37.90	
1900	1.37	1.38	21.11	81	0.41	-37.10	
2000	1.34	1.42	21.17	67	0.41	-37.00	
2100	1.31	1.43	21.22	51	0.43	-36.60	
2200	1.28	1.45	21.32	36	0.42	-35.90	
2300	1.24	1.50	21.47	20	0.45	-35.30	
2400	1.19	1.52	21.60	3	0.46	-35.00	
2500	1.15	1.58	21.75	-14	0.49	-34.80	
2600	1.16	1.68	21.92	-33	0.52	-33.80	
2700	1.27	1.79	22.04	-53	0.55	-33.40	

Model: AR2538		LINEAR S-PARAMETERS								Icc=189.19	
		Vcc=+15V				S22					
FREQ	S11	S21	S12	S22	MAG	ANG	MAG	ANG	MAG	ANG	
5	0.48	-41.00	5.41	117.50	0.02	3.30	0.65	-168.80			
10	0.31	-60.90	10.88	64.60	0.02	-0.50	0.44	157.90			
15	0.21	-66.20	12.43	41.00	0.02	-1.50	0.31	148.50			
20	0.16	-65.80	12.81	28.30	0.01	0.50	0.25	149.00			
50	0.09	-53.10	12.86	3.80	0.01	0.70	0.18	160.40			
100	0.07	-53.30	12.57	-11.00	0.02	-2.50	0.16	161.70			
150	0.07	-46.70	12.28	-18.90	0.02	-5.00	0.15	174.50			
200	0.11	-52.50	12.02	-25.80	0.02	-9.50	0.17	168.80			
250	0.12	-69.80	12.37	-32.30	0.02	-14.10	0.16	164.50			
300	0.12	-79.10	12.62	-40.50	0.01	-18.70	0.15	166.40			
350	0.13	-86.20	12.70	-48.40	0.01	-16.80	0.15	168.00			
400	0.14	-91.90	12.75	-56.40	0.02	-17.70	0.15	168.10			
500	0.15	-101.20	12.73	-72.00	0.01	-24.00	0.16	165.90			
600	0.17	-108.50	12.65	-87.30	0.01	-29.70	0.17	162.70			
700	0.18	-115.30	12.54	-102.60	0.01	-32.10	0.18	158.30			
800	0.19	-121.50	12.46	-117.50	0.01	-37.80	0.19	151.50			
900	0.20	-126.80	12.31	-132.50	0.01	-45.10	0.19	144.80			
1000	0.21	-131.20	12.19	-147.10	0.01	-48.20	0.19	137.00			
1100	0.21	-135.40	12.10	-161.90	0.01	-49.50	0.19	127.60			
1200	0.22	-138.40	12.01	-176.80	0.01	-61.00	0.19	118.60			
1300	0.21	-142.90	11.88	168.10	0.01	-69.40	0.18	109.50			
1400	0.20	-147.40	11.64	153.50	0.01	-69.50	0.18	94.10			
1500	0.19	-147.60	11.52	139.40	0.01	-83.40	0.17	80.30			
1600	0.18	-147.20	11.44	125.00	0.01	-89.80	0.16	64.30			
1700	0.17	-147.40	11.35	110.50	0.01	-98.20	0.16	46.80			
1800	0.16	-147.30	11.38	96.10	0.01	-106.10	0.16	32.70			
1900	0.16	-145.30	11.36	81.40	0.01	-115.20	0.16	15.30			
2000	0.15	-143.20	11.44	66.70	0.01	-129.10	0.17	1.00			
2100	0.13	-140.60	11.51	51.30	0.02	-132.90	0.18	-9.60			
2200	0.12	-136.90	11.64	36.10	0.02	-142.90	0.18	-22.40			
2300	0.11	-131.30	11.84	19.70	0.02	-156.50	0.20	-30.20			
2400	0.09	-121.50	12.02	3.30	0.02	-164.90	0.21	-35.10			
2500	0.07	-100.10	12.23	-14.20	0.02	-177.00	0.22	-40.60			
2600	0.07	-65.20	12.47	-32.90	0.02	176.00	0.25	-44.20			
2700	0.12	-40.50	12.65	-52.60	0.02	165.50	0.28	-49.40			