

A2CP5008

2000-5000 MHz COUGARPAK™ AMPLIFIER

Typical Values	A2CP5008
High Power Output	+24.5 dBm
Medium Gain	12.0 dB
Low Noise Figure	3.0 dB
High Performance Thin Film Two-stage CougarPak™ Package	

SPECIFICATIONS*

Parameter	Typical	Guaranteed	
		0 to 50 °C	-55 to +85 °C
Frequency (Min.)	1800-5000 MHz	2000-5000 MHz	2000-5000 MHz
Small Signal Gain (Min.)	12.0 dB	10.5 dB	10.0 dB
Gain Flatness (Max.)	±0.7 dB	±1.0 dB	±1.2 dB
Noise Figure (Max.)	3.0 dB	3.7 dB	4.2 dB
SWR (Max.) Input/Output	1.5:1	1.7:1	1.7:1
Power Output (Min.) @ 1dB comp.	+24.5 dBm	+23.5 dBm	+23.0 dBm
Reverse Isolation	24 dB	—	—
DC Current (Max.)	250 mA	265 mA	280 mA

* Measured in a 50-ohm system at +12 Vdc unless otherwise specified.

INTERMODULATION PERFORMANCE

Typical @ 25 °C	A2CP5008
Second Order Harmonic Intercept Point	+56 dBm
Second Order Two Tone Intercept Point	+50 dBm
Third Order Two Tone Intercept Point	+35 dBm

ABSOLUTE MAXIMUM RATINGS

Storage Temperature	-62 to +125 °C
Maximum Case Temperature	+125 °C
Maximum DC Voltage	+14 Volts
Maximum Continuous RF Input Power	+22 dBm
Maximum Short Term Input Power (1 Minute Max.)	+25 dBm
Maximum Peak Power (3 μsec Max.)	+28 dBm
Burn-in Temperature	105 °C
Thermal Resistance ¹ (θjc)	+15 °C/Watt
Junction Temperature Rise Above Case (Tjc)	+45 °C

¹ Thermal resistance is based on total power dissipation.

A2CP5008

CougarPak™ SMA Package (two-stage)

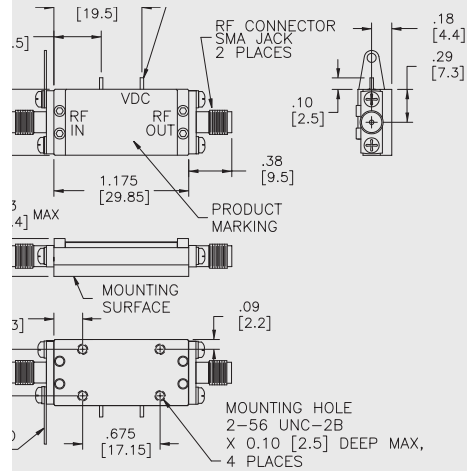

Package only sold with SMA connectors and base mounting plate; both can be removed. Pin package for reference only.

A2CP5008

CougarPak™ Pin Package (two-stage)

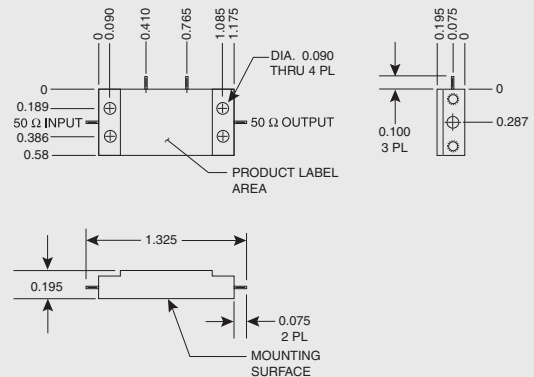

DIMENSIONS ARE IN INCHES [MILLIMETERS]